

SPECIFICATIONS

Weight with cable and pipe shank:	1125 lbs.
Weight with fabric chute:	1250 lbs
Width with legs on ground:	50"
Length with cable and pipe shank:	71"
Length with fabric chute:	114"
Height:	64"
Maximum depth with coulter:	16"
Maximum depth without coulter:	22"
Pipe and cable shank:	1" x 6" shank
Offset at 30 degree position:	16" from center of power unit R/L side
Offset at 60 degree position:	26" from center of power unit R/L side
Standard cutting coulter:	16" fluted spring loaded coulter
Turning angle:	Rear pivot design has 90 degrees R/L
Vibratory Unit:	7000 lbs. @ 2200 rpm
Flow control:	Flow control valve for amount of vibration
Isolators:	Rubber shock Isolators incorporated on vibratory

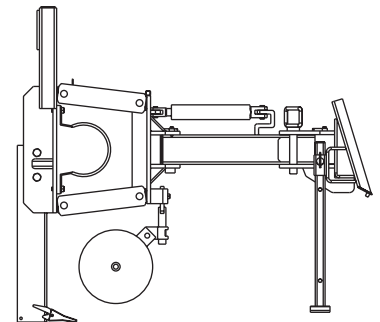
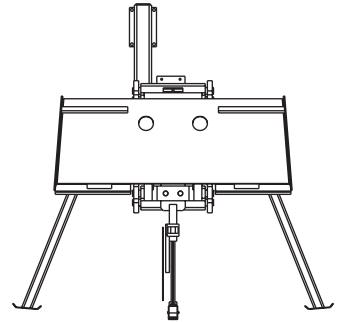
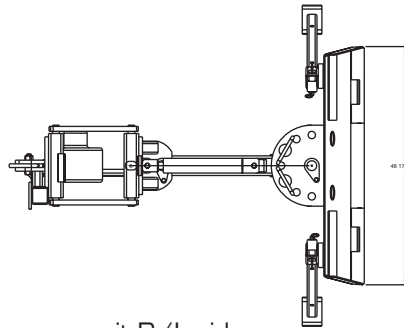

Optional equipment:

Silt Fence Installation Fabric Chutes for 36", 42" or 48" fabric
Tractor or skid loader mounting brackets
Cable spool holders